

# BREAKERBOSS 5D

## Mobile Rockbreaker

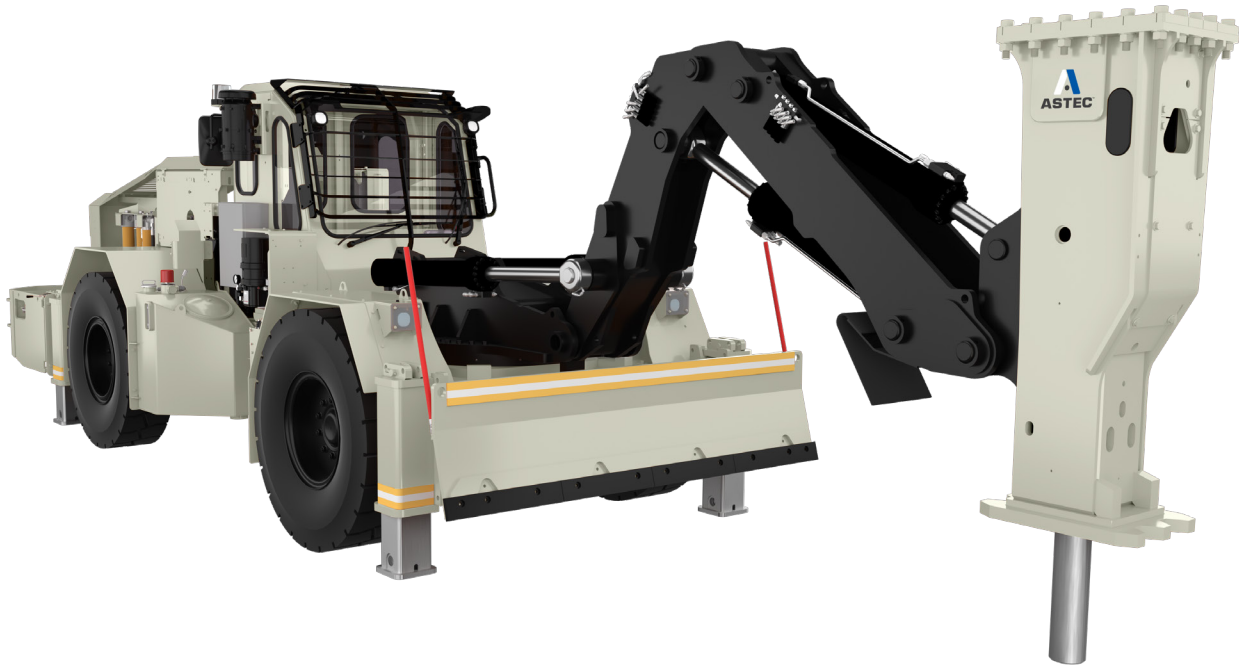

### Boom

- Standard Breaker of 6780 J (5000 ft-lbs) with the option of 8810 J (6500 ft-lbs) breaker
- BXR65 is largest in class
- Large boom coverage capacity with 3 m (9.84 ft) vertical reach and 4 m (13.12 ft) horizontal reach
- Swing range of +/- 30 degrees
- Rugged frame resists twisting and shock loading
- Engineered sections fabricated from high-strength carbon steel with reinforced ends
- Oversized alloy steel pivot pins with replaceable bushings
- Cylinders equipped with oversized rods and self-aligning bushings at each end to prevent side loading of cylinders during raking and breaking operations
- Proportional electro-hydraulic controls for boom functions, on/off for breaker fire and 24V solenoids

### Cab

- ROPS/FOPS certified
- Sealed cabin with filtered fresh and recirculated air
- Excellent visibility

### Engine

- Deutz TCD2012L062V 132 kW (177 hp) Tier 3 MSHA
- Dry element engine air intake with safety element
- Catalytic exhaust purifier/silencer

### Carrier

- Four-wheel drive
- Articulated, all-welded, heavy-plate construction with engine end-axle oscillation
- Spherical roller-bearing articulation joint designed for long life
- Articulation/steer angle of +/- 45 degrees
- Central manual greasing system for steer cylinders and center articulation joint
- Reinforced stabilizers to ensure stiffness and stability during breaking operations
- Electric/hydraulic powerpack option to reduce emissions when rock breaking

### Controls

- Excellent ergonomics
- Joysticks in operator seat armrests
- CAN-Bus-based control design
- Programmable hydraulic controls for fast and smooth boom functions
- Wireless radio remote control option

## Options

- Choice of breaker tool: blunt, chisel ormoil
- Pusher blade
- Breaker automatic lube system
  - 16 L electric- driven lube pump
  - Uses chisel paste
- Boom and carrier automatic lubrication system
  - 8 L electric driven lube pump and dedicated grease injectors for each lubrication point on rock breaking boom and carrier pin connections
- Dust suppression system
  - 24V pump c/w 75 gal (284 L) holding tank with mine water hook-up
- Fire suppression
  - ANSUL LVS-30 liquid chemical
  - Six nozzle
  - Manually activated
- Spare tire (14.00R24 heavy-duty mining tire) and rim assembly
- Radio remote control
  - Line of sight control for rock breaking boom system and tram functions for distance up to 50 m (160 ft)
- Choice of engine
  - Deutz TCD2013L06 110kW (148 hp) at 4500 masl
  - Deutz TCD6.1T4F 129kW (172 hp)
- Data link (remote machine monitoring)
  - Industrial communication protocol interface for data transfer from Astec control system to customer's external system (DCS, PLC or SCADA)
  - Ability to transmit machine faults, warnings, machine hours and instrument status to the customer's process and control system

## BXR50C Hydraulic Breaker

Dimension	Imperial	Metric
Impact Energy	5,000 ft-lbs	6,780 J
Impact Rate	440 - 810 bpm	
Hydraulic Pressure	2,700 psi	186 bar
Oil Flow	42-53 gpm	160-200 lpm

## BXR65C Hydraulic Breaker

Dimension	Imperial	Metric
Impact Energy	6,500 ft-lbs	8,810 J
Impact Rate	400 - 800 bpm	
Hydraulic Pressure	2,700 psi	186 bar
Oil Flow	46-58 gpm	175-220 lpm

## Carrier

Dimension	Imperial	Metric
Weight	55,891 lb	25,352 kg
Height	9' 3"	2.8 m
Width	8' 8"	2.6 m
Length	34'	10.3 m
Inside Turning Radius	11' 2"	6.36 m
Outside Turning Radius	20' 11"	15.21 m
1st Gear	4.8 mph	7.7 kph
2nd Gear	7 mph	11.2 kph
3rd Gear	13.2 mph	21 kph

