

PETERSON HORIZONTAL GRINDERS



STRONG AND EFFICIENT

Don't limit your products or your profitability. Improve the quality of your raw materials with the grinding system that produces the most consistent end products. Peterson grinders feature an intelligent adaptive feed system that helps manage the grinding process. Featuring one of the largest grate areas in the industry, when combined with our easy-change tooling system, Peterson grinders can help you maximize your profitability.



Green Waste Recycling



Wood Waste Recycling



Land Clearing



Construction & Demolition Recycling



Asphalt Shingle Recycling



Storm Debris Cleanup



Municipal Solid Waste



Railroad Tie Recycling

We offer grinding operators the right tools for the right job: innovative machinery with the ability to produce a wide array of products that satisfy customer demands. Examples of the diverse output Peterson grinders can produce include a fuzzy, stringy material with good bulking characteristics, which has good erosion control characteristics. At the other end of the spectrum is a chunky product with reduced fines. Production can be fine-tuned based on the feed stock, such as fresh cut round wood, which yields a different end product than recycled pallets and has substantially different grinding characteristics.



Mulch

Created from wood and green waste reducing waste from landfills. Our four grate system allows for a variety of output specifications.



Compost

Created from wood, food, and green waste recycling initiatives. Our grinders turn a low-value material into a high-value product.



Biofuel

Turn wood waste, forest & sawmill residuals, and even agricultural products into biofuel.

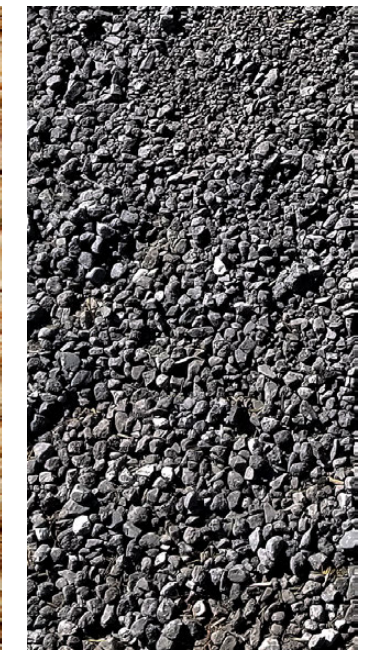

Asphalt Shingles

Recycled Asphalt shingles can be salvaged for road building diverting materials from landfills while potentially reducing road building costs.





LOWEST COST PER TON

Astec offers a full-line of Peterson horizontal grinders from 455–1200 horsepower (339–894 kW), in both diesel and electric applications to suit your grinding needs. Peterson grinders offer industry leading features and innovations which allow you to produce the highest quality product at the lowest cost per ton.

The Peterson grinders’ powerful upturn 3-stage grinding process provides better fracturing of material and a more consistent product, giving you just the product your buyers are looking for.

Astec’s Peterson Grinders feature upturning rotors that are ideally configured to produce lighter mulches with fewer fines. Down-turning rotors accomplish more of the reduction process with a compressive fracture of the wood that tends to produce more fines. Our upturning rotor will perform more of the reduction process through shearing and cleavage fractures in the wood.

The Peterson horizontal grinders are more productive since less energy is required to reduce the wood with these fracture modes. The difference in profitability at the end of the year can be dramatic with lower fuel consumption, lower colorant cost, and higher mulch yield.

DURABILITY & PERFORMANCE

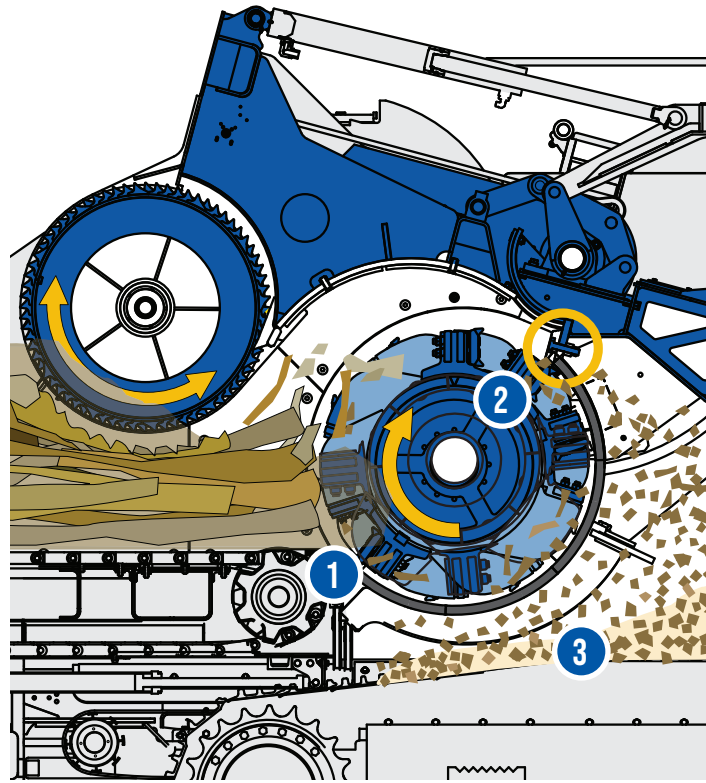

3-STAGE GRINDING PROCESS

The machine uses an upturning rotor in combination with a down-force compression roll to grind the feed material in a three-stage process, resulting in more accurate and consistent finished products.

- 1 Up-turning Rotor**
Opposing rotational forces create an aggressive shearing action. The up-turn rotor draws material into the grinding chamber and minimizes bit wear. Provides the first stage in material size reduction. Available with pinned or drum rotors.
- 2 Anvil**
Positioned for optimum sizing and production, the anvil provides the second stage in the sizing process.
- 3 Grate Area**
The last step in the 3-stage sizing process, the large grate area results in high-production of a wide variety of materials and end products.

ENDLESS POSSIBILITIES

Peterson horizontal grinders can be utilized for different jobs by swapping out tooling. Change out bits and grates for a new end product. Peterson's four-grate system means smaller grates to provide for more customizing. Peterson's high-quality bits and grates offer superior life and fit and finish.

Peterson horizontal grinders have the most tooling options from bits to grates in hex, round, square, and rectangle openings. In addition, the four-piece grate system permits you to mix and match to achieve the desired product; this tooling works well in both the initial grind and regrind steps.

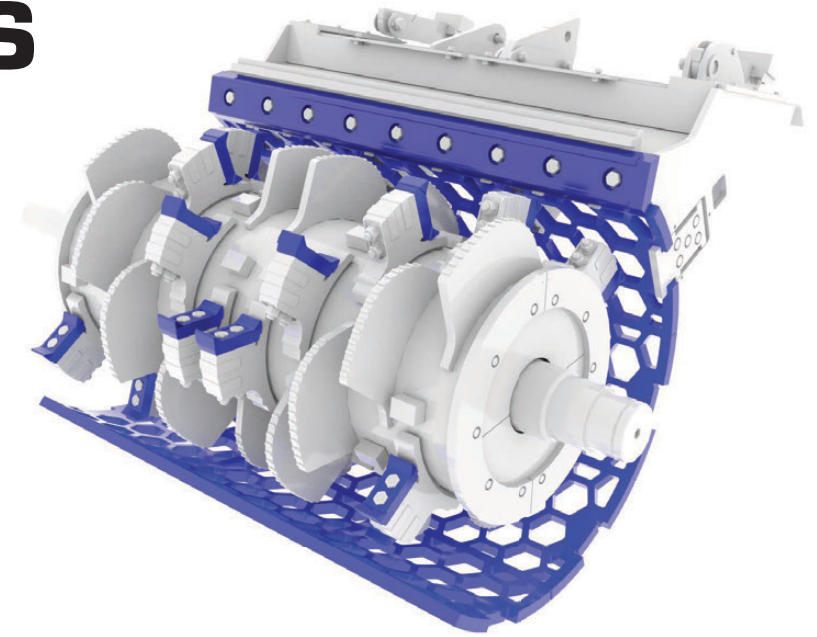

PROTECT YOUR INVESTMENT

IMPACT RELEASE SYSTEM

The Impact Release System (IRS) helps prevent damage to the machine when a large ungrindable object enters the feed.

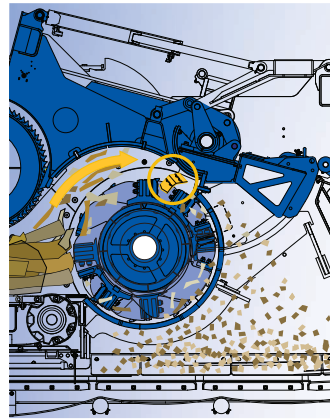

1 Ungrindable Object Detected

Peterson horizontal grinders incorporate a patented Impact Release System™ that minimizes damage to the grinding chamber from ungrindable objects.

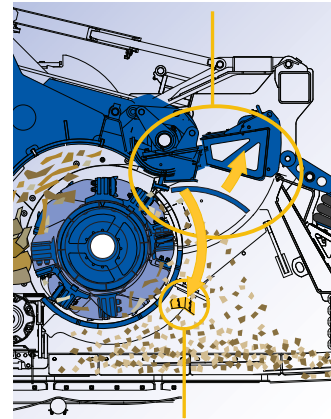

2 Safety System Initialized

The Impact Release System opens the anvil and first grate section to eject ungrindable objects from the grinding chamber.

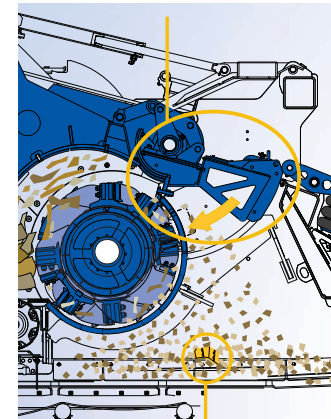

3 Ungrindable Object Ejected

The machine now returns to normal operation. This results in more uptime and less costly damage from heavy contamination in the feed material.

OPERATOR EXPERIENCE



Remote Control

The remote control operates the entire system, enabling a single-person application. Pause and resume operation with the push of a button.



Easy Touch Screen

The IQAN control panel has a user-friendly design and allows for fine-tune adjustments for maximum productivity.



Safety First

Astec builds equipment with safety in mind. The Impact Cushion System, Thrown Object Safety Guard, and high visibility safety rails provide for a safer job.



KEY FEATURES

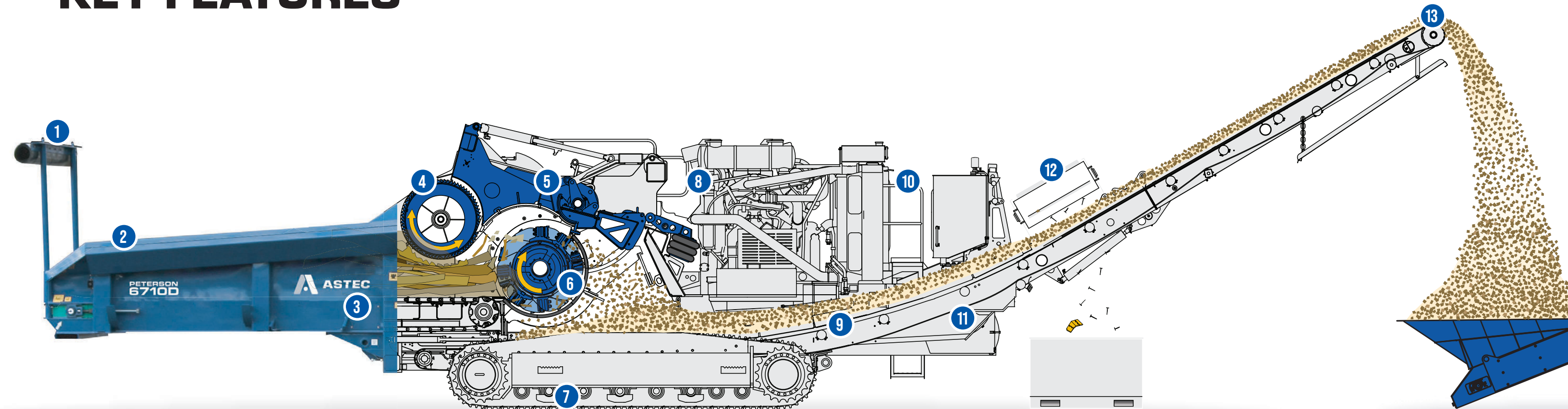

1 Safety Guards

Peterson horizontal grinders are built with safety in mind, including the projectile guard.

2 Sloped Feed Walls

Allow better visibility while loading and smoother feeding for more production in a wide variety of materials.

3 Feed Chain Conveyor

A robust feed chain conveyor efficiently feeds the rotor. A hydraulic drive motor synchronizes with the feed roll for near continuous feeding and massive throughput.

4 Adaptive Feed System

Monitors the grinding load and varies the speed of the feed system to keep the engine working at its optimal power curve. It accelerates the feed when the engine load is light, slows when the load is high, and reverses feed when the load is excessive.

5 Impact Cushion System

Absorbs energy shocks and spikes to extend grinding system component life and helps prevent catastrophic damage from severe impact.

6 Rotor Placement

Optimum rotor placement ensures positive feeding and reduces the potential of thrown material. Pinned or drum rotors are available.

7 Mobility Options

Astec horizontal grinders are available in wheeled, tracked, or stationary electric versions. Larger tracked grinders have an optional tow dolly for easy transport, while the 1700D can be towed with a dump truck.

8 Multiple Engine Options Available

Depending on emission standards for your region, Astec offers both Tier II, Tier IV, and EU Stage V engine configurations.

9 Continuous Discharge Conveyor

One continuous discharge conveyor reduces material loss, increases uptime, and lowers maintenance.

10 Guard Rails

With safety in mind, guardrails are high-visibility yellow, reducing potential slip & fall hazards when servicing the machine.

11 IQAN Operating System

Fine-tune adjustments for maximum productivity.

12 Optional Cross Belt Magnet

Powerful cross-belt magnets pull tramp metal off of the conveyor, producing cleaner, profitable material. Earn additional income from scrap metal!

13 Optional Magnetic Headroll

Peterson grinders feature a magnetic headroll that allows for effective metal separation and high capacity production.

OPTIONAL EQUIPMENT



Standard Drum Rotor

Hammers are welded onto a smooth drum surface. Drum rotors are best for applications with low contamination feedstock for longer wear. Drum rotors typically produce a more consistent end product than pinned rotors.



Pinned Rotor

Hammers are secured by large pins. Pinned rotors are best for contaminated applications, allowing faster part replacement due to damage. It also prevents the replacement of a whole rotor in the case of contaminated materials.

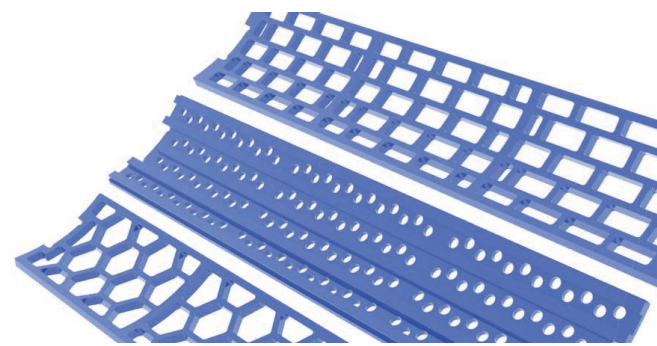

Customizable Configurations

While the hex grate is king, square, round, rectangle, and even custom grates are available. Grates are also available with baffles to reduce spearing, or additional breaker anvils for additional size reduction.

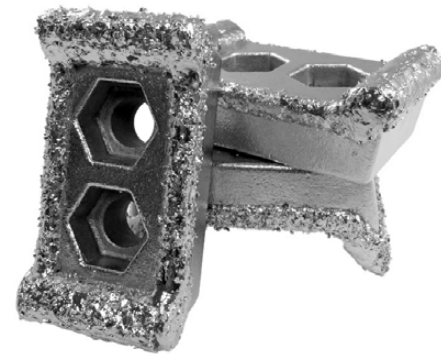

Bits for Every Application

With seven different bits to choose from, a grinder's tooling can be customized for different feedstocks and required outputs.



Cold Weather Kit

When operating in temperatures below freezing, diesel and electric cold weather kits are available. The cold weather kit helps heat the engine block and the hydraulic oil, which allows for smoother starts after machine down time and keeps the engine warm while in operation.

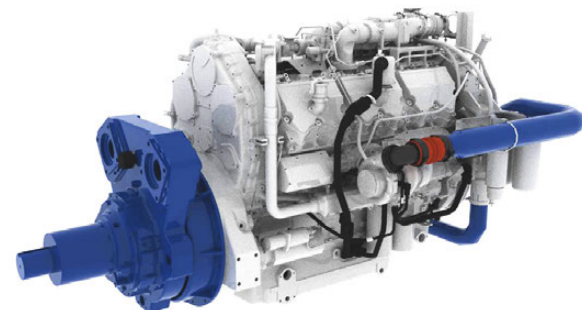

Engine Packages

Peterson horizontal grinders are available with a variety of engine package options, including engine packages to suit your local emissions requirements. CE certification is also available for our most popular models.



Transportation Dolly

Our optional transportation dolly offers the mobility of tracks with the ease of transportation of wheels to help you move your machine between jobs without needing a low-boy.

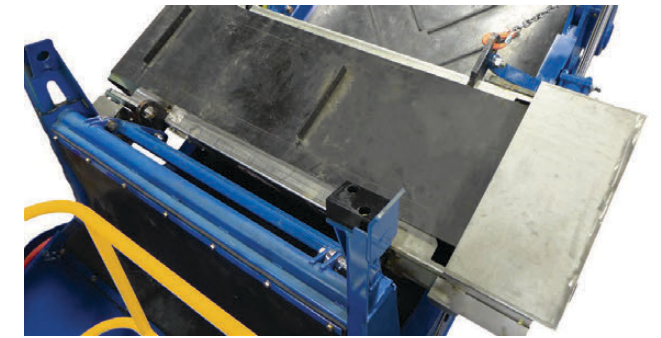

Crossbelt Magnet

Crossbelt Magnets are used in applications where metal contamination is a factor. They are mounted above the discharge belt to remove and recover metal, generally with a much higher recovery rate than a head pulley magnet. The metal collection box can be added to the crossbelt magnet.

Equipment Options

	1700D	1710D	2710D	2750D	4710D	4750D	5710E	6700D	6710D	6750D
Magnetic Head Pulley	•	•	•	•	•	•	•	•	•	•
LED work Lights	•	•	•	•	•	•	•	•	•	•
Dust Control	•	•	•	•	•	•	•	•	•	•
Crossbelt Magnet	•	•	•	•	•	•	•	•	•	•
Scrap Metal collection box			•	•	•	•	•	•	•	•
Export kit	•	•	•	•	•	•	•	•	•	•
CE Certification	•	•	•		•		•	•	•	
Feed Tailgate	•	•	•	•	•	•				
Cold Weather Kit			•		•		•	•	•	
Air Compressor					•			•	•	•
R+ Package					•	•		•	•	•
ASG Package			•	•	•	•				
Flat Feed Deck	•	•		•						
Liquid Injection System	•	•	•							
Tow Dolly			•		•		•			
Short Discharge Conveyor	•	•								
Extra-Long Discharge Conveyor	•	•		•			•			

R+ PACKAGE

Grind the Toughest Materials

The weakness of many slow-speed shredders is low throughput, and high-speed grinders can be vulnerable to contaminated materials. The R+ Package is the best of both worlds—the output of a high-speed grinder with the protection of a slow-speed shredder.

Astec's innovative R+ Package can transform our grinder into a mid-speed unit, which is ideal for Construction & Demolition

(C&D) or Municipal Solid Waste (MSW) applications. The heart of our machine has been upgraded with heavier duty components designed to withstand the rigors of reducing these types of materials. The machine can be reversed back to a high-speed grinder in a day, if the application requires it—a feature not found with any other grinder on the market. High production, robust components, and superior product protection make this a valuable investment.

Typical R+ Applications

Your Peterson grinder with the R+ Package enables you to bid on projects that other machines can't handle. Strong, productive, and robust, the R+ Package can give you the competitive advantage.



C&D Recycling



Storm Debris



Municipal Solid Waste



Railroad Ties

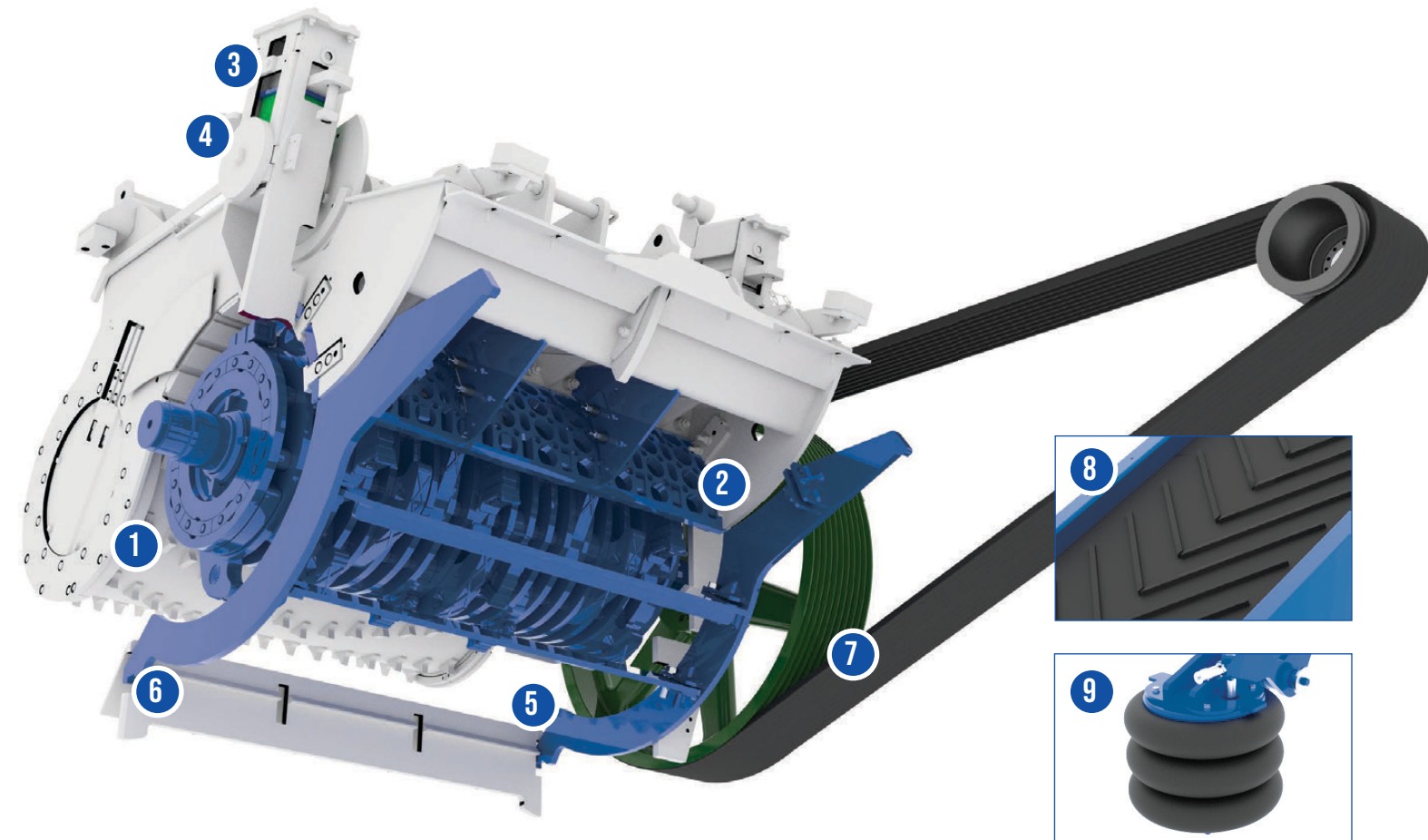

1 R+ Rotor

Heavy duty and robust, the R+ rotor's asymmetrical pattern of high & low bits create an aggressive shearing action with the comb grate.

2 Comb Grate

The comb grate is a heavy-duty grate with additional shearing area, allowing material to be fractured across many surfaces. The three lower grate positions remain empty for material to easily exit the grinding chamber.

3 Larger Shear Pin

Allows a dramatic increase of force needed to trip the Impact Release System.

4 Cushion Blocks

Increased hardness to allow the Impact Release System (IRS) to absorb harder hits.

5 Baffle Plate

Reinforced steel for heavier impacts from ejected materials.

6 Grate Supports

Modified grate supports allow for multiple baffle plate placements.

7 Sheave

The larger sheave decreases the rotor speed in half, allowing the rotor to sustain less damage from impact while creating more torque to efficiently power through heavy materials.

8 Heavy Duty Conveyor Belt

A heavy duty conveyor belt combined with an increased discharge clearance allows for larger volume of materials and superior belt life.

9 R+ Air Bags

Air bags allow more materials to pass through the grinding chamber without unnecessary machine shutdowns, but still offers protection by opening the Impact Release System if an ungrindable object is encountered.

* Operators must ensure waste material does not contain hazardous or regulated substances requiring special handling.

ASPHALT SHINGLE PACKAGE

Enabling Environmental Sustainability

The unique design of Astec's horizontal grinders makes them well suited to reduce asphalt shingles into a product that is an excellent ingredient for hot mix asphalt. Minimizing oversized material is an important factor in providing consistent, high-quality asphalt.

Recycling asphalt shingles into asphalt pavement mixtures provides a sustainable solution reducing landfill waste.

Grinding asphalt shingles is highly abrasive, and often needs specialty equipment. Peterson's horizontal grinders combined with high abrasive bits, water injection, and our Anvil Breaker Grate can create a product to your customer's exact specifications.



Cast Carbide Bits

Cast carbide bits are designed specifically for this application to extend bit life.



ASG Grates

500 Brinell Hardox grates or Carbide Overlay grates are available to produce the required product specification.



Water

Water spray bars facilitate lubrication and cooling when grinding asphalt shingles, plus minimize airborne material.



Bolt-In Liners

Bolt-in AR500 liners in the sidewalls of the grinding chamber and bottom of the compression roll housing extend the life of the machine.

ELECTRIC SOLUTIONS

Clean Energy Meets Lower Operating Costs

The benefits are clear; electric grinders cost less to operate, produce less noise and have unmatched uptime. No matter what your site requirements may be, Astec's experienced engineering team can design an entire system to meet your needs.

Soft-Start or VFDs

Not certain about power integration requirements? Astec offers a choice of soft-start or Variable Frequency Drives (VFDs) for best integration with your electrical power source for a tailored solution.



Electrical Motors

Electric grinders are offered in a wide range of power levels, with crusher-duty electric motors ranging from 400 to 1300 hp.



Ethernet Communications

Siemens PLC Control System is an industrial grade control system that can be easily networked to a remote plant control computer.



Controls

Easily monitor system performance. The fully integrated, industrial grade Siemens PLC interface is user-friendly and customizable to your application.



Control Houses

Astec can provide a complete solution for your grinding yard, including control houses, platforms, and other add-ons.



MODELS

No matter what your grinding application, Astec has a Peterson horizontal grinder to suit your needs. From pallet grinding applications to storm debris or land clearing operations, we have a solution for you.

The Peterson grinder line is offered in wheel, tracked, or stationary electric applications as illustrated in the tables on these pages.

Essentially, a countless number of combinations are possible with Peterson grinders, enabling mulch producers to generate the highest quality product with the greatest efficiency, and all at the lowest cost per ton.

The machine that makes the “right-sized” particle out of randomly sized feed materials contributes the most value. Whether your end products are mulch or compost in bulk form or packaged for retail, Peterson horizontal grinders can contribute value to your bottom line profits. The combination of features and innovations makes Peterson horizontal grinders ideal machines for most size reduction jobs.



1700 Series

Details	Spec
Standard Diesel Engine	CAT C9.3B Tier IV, 455 hp (EU Stage V, 339 kW)
Feed Opening (width x height)	54" x 27" (137 x 69 cm)
Number of Bits	22 (drum), 18 (pinned)
Green Waste*	140 yd ³ (107 m ³)
Scrap Board*	185 yd ³ (141 m ³)

1700 Wheeled Specifications

Operating Height	14' 7" (445 cm)
Operating Length	44' 1" (1344 cm)
Travel Length	36' 3" (1104 cm)
Travel Width	8' 4" (255 cm)
Machine Weight	41,000 lbs (18 597 kg)

1710 Tracked Specifications

Operating Height	14' 1" (429 cm)
Operating Length	41' 1" (1250 cm)
Travel Length	33' 1" (1009 cm)
Travel Width	8' 2" (250 cm)
Machine Weight	46,500 lbs (21 092 kg)



2700 Series

Details	Spec
Standard Diesel Engine	CAT C15 Tier IV, 580 hp (433 kW)
Feed Opening (width x height)	60" x 32" (153 x 81 cm)
Number of Bits	20 (drum), 18 (pinned)
Green Waste*	300 yd ³ (229 m ³) per hour
Scrap Board*	368 yd ³ (281 m ³) per hour

2710 Tracked Specifications

Operating Height	15' 9" (480 cm)
Operating Length	52' 11" (1612 cm)
Travel Length	40' 8" (1241 cm)
Travel Width	8' 2" (250 cm)
Machine Weight	68,100 lbs (30 900 kg)

2750 Electric Specifications

Standard Rotor Drive Motors	460 volt, 60Hz, 600 hp (447 kW)
Operating Height	52' 6" (16 m)
Operating Length	9' 1" (277 cm)
Travel Length	39' 11" (1217 cm)
Travel Width	9' 1" (277 cm)
Machine Weight	54,000 lbs (24 500 kg)



4700 Series

Details	Spec
Standard Diesel Engine	CAT C18 Tier IV, 755 hp (563 kW)
Feed Opening (width x height)	60" x 38" (152 x 97 cm)
Number of Bits	22 (drum), 20 (pinned)
Green Waste*	360 yd ³ (275 m ³)
Scrap Board*	425 yd ³ (325 m ³)

4710 Tracked Specifications

Operating Height	16' 8" (508 cm)
Operating Length	56' 9" (1730 cm)
Travel Length	44' 11" (1369 cm)
Travel Width	9' 10" (299 cm)
Machine Weight	79,000 lbs (35 834 kg)

4750D Electric Specifications

Standard Rotor Drive Motors	460 volt, 60Hz, 600 hp (447 kW)
Operating Height	17' 3" (526 cm)
Operating Length	60' 5" (1842 cm)
Travel Length	47' 5" (1446 cm)
Travel Width	9' 11" (301 cm)
Machine Weight	71,500 lbs (32 432 kg)



5700 Series

Details	Spec
Standard Diesel Engine	CAT C27 Tier IV, 1050 hp (782 kW) Optional: CAT C32 Tier IV, 1125 hp (839 kW)
Feed Opening (width x height)	60" x 40" (152 x 102 cm)
Number of Bits	22 drum rotor
Green Waste*	501 yd ³ (383 m ³)
Scrap Board*	591 yd ³ (452 m ³)

5710 Tracked Specifications

Operating Height	17' ½" (520 cm)
Operating Length	58' 1 ¾" (18 m)
Travel Length	46' 6 ¼" (1418 cm)
Travel Width	9' 9 ¾" (299 cm)
Machine Weight	88,500 lbs (40,143 kg)
- with Transportation Dolly	100,200 lbs (45,450 kg)

Optional Transportation Dolly Specifications

Length	16' 5 ⅞" (501 cm)
Width	8' 6" (259 m)
Front to First Axle	3' 9 ⅛" (23 cm)
Axle Spacing	5' (152 cm)
Ride Height Range - Minimum	6 ⅛" (17.6 cm)
- Maximum	1' 7 ⅛" (50.1 cm)
- Transport	1' 2 ¾" (37.5 cm)
Height Range - Minimum	5' 3 ½" (161.33 cm)
- Maximum	6' 9 ¼" (206.43 cm)
- Transport	6' 4 ⅞" (193.83 cm)



6700 Series

Details	Spec
Standard Diesel Engine	CAT C32 Tier IV, 1125 hp (839 kW)
Feed Opening (width x height)	66" x 50" (168 x 127 cm)
Number of Bits	22 (drum), 18 (pinned)
Green Waste*	583 yd ³ (446 m ³)
Scrap Board*	653 yd ³ (499 m ³)

6700 Wheeled Specifications

Operating Height	17' 6" (534 cm)
Operating Length	62' 11" (19 m)
Travel Length	51' (1562 cm)
Travel Width	11' 1" (338 cm)
Machine Weight	98,000 lbs (44 452 kg)

6710 Tracked Specifications

Operating Height	16' 11" (515 cm)
Operating Length	60' 11" (1857 cm)
Travel Length	49' (1493 cm)
Travel Width	12' (364 cm)
Machine Weight	108,500 lbs (48 987 kg)

6750 Electric Specifications

Standard Rotor Drive Motors	460 volt, 60Hz, 1200 hp (895)
Operating Height	17' 6" (534 cm)
Operating Length	62' 10" (19.15 m)
Travel Length	51' 1" (1562 cm)
Travel Width	10' 7" (323 cm)
Machine Weight	103,000 lbs (46 720 kg)

*Actual production output may vary due to moisture content, material density y and size, support equipment, grate size, and equipment options. Production rates are based on operating 50 minutes per hour with the standard diesel engine.



www.astecindustries.com