

# CS4250

## Portable HSI Plant

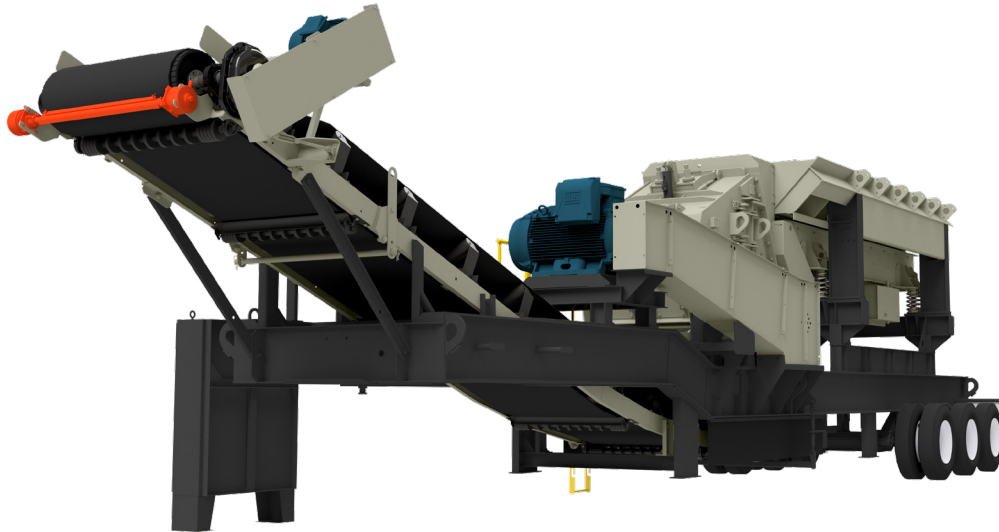

### Hopper / Vibrating Grizzly Feeder Module

- 3/4" fabricated steel hopper and supports
- 50" x 20' horizontal type oil bath feeder
- 5' replaceable and adjustable grizzly section standard
- Grizzly spacing 1" to 5", specified at order
- 3/4" mild steel deck liner
- 40 HP motor, adjustable motor mount and v-belt drive

### Impact Crusher - HSI

- HSI feed opening 50" (1270mm) x 36" (914mm)
- Apron setting range 2" - 6" (51 mm x 152mm) upper
- 1" - 4" (25mm x 102mm) lower
- 450 - 625 RPM / 4950 - 6875 FPM rotor speed range
- MPR segmented rotor design
- Fully lined chamber and apron with abrasion resistant steel liners
- Hydraulic adjustment for easy crusher setting
- Hydraulically activated rear access door

### End Delivery Conveyor

- 48" channel frame
- Belt cleaner
- Screw take-up belt tension
- 20 HP motor, mount, drive, and guarding

### Chassis

- Semi-trailer with triple rear axle
- Rear crib leg and king pin support
- Twelve 11:00 x 22.5 dual mounted tires
- Air brakes, travel lights, mudflaps
- Motor mount and v-belt drive for optional power
- Bypass chute under grizzly module
- Service platforms behind crusher

### Options

- Reverse configuration with hopper over king pin (allows for longer end delivery and higher discharge)
- 200 HP TEFC electric motor at 1200 RPM
- 200 HP starter and 60' of cable
- Electric motor controls for basic plant (excluding crusher) NEMA-12 remote panel box with feeder VFD
- Grease lubrication for feeder in lieu of oil bath
- Extension brackets for feed hopper (less planks)
- Impact bed on end delivery conveyor
- Magnet and support
- 24" x 15', 5 HP side delivery conveyor
- Hydraulic jacks (4) with 18" stroke for cribbing
- Hydraulic run-on plant raising and leveling system (4) with 24" stroke
- 8 HP gas (electric start) or 5 HP electric power pack for hydraulic jack system
- 4 bar rotor vs. standard 3 bar
- Dust suppression system with manifold
- Consult factory for additional hopper, crusher, conveyor, axle, jack, and power options

## Physical/Operating Characteristics

Dimension	Standard	Metric
Operating Length	55' 7"	16.9m
Travel Length	48' 8"	14.8m
Operating Height	13' 5"	4.1m
Travel Height	13' 3"	4.0m
Ground Clearance	13"	0.3m
Total Weight (basic plant)	94,000 lb.	42,640 kg
Travel Weight (basic plant)	69,460 lb.	31,505 kg
End Delivery Conveyor	6,550 lb.	2,970 kg
Feeder & Hopper	24,540 lb.	11,130 kg

Dimension	Standard	Metric
Operating Width	11' 11"	3.6m
Operating Width w/ Discharge	15' 11"	4.8m
Travel Width	10' 11"	3.3m
Feed Height	13' 3"	4.1m
Discharge Height	10' 7"	3.2m
Side Discharge (optional)	5' 1"	1.5m
Basic Motor Controls & Panel	660 lb.	300 kg
Electric Motor & Starter	3,900 lb.	1,770 kg
Optional Side Delivery	1,700 lb.	770 kg