

# SS10

## Mobile Direct Feed Screen

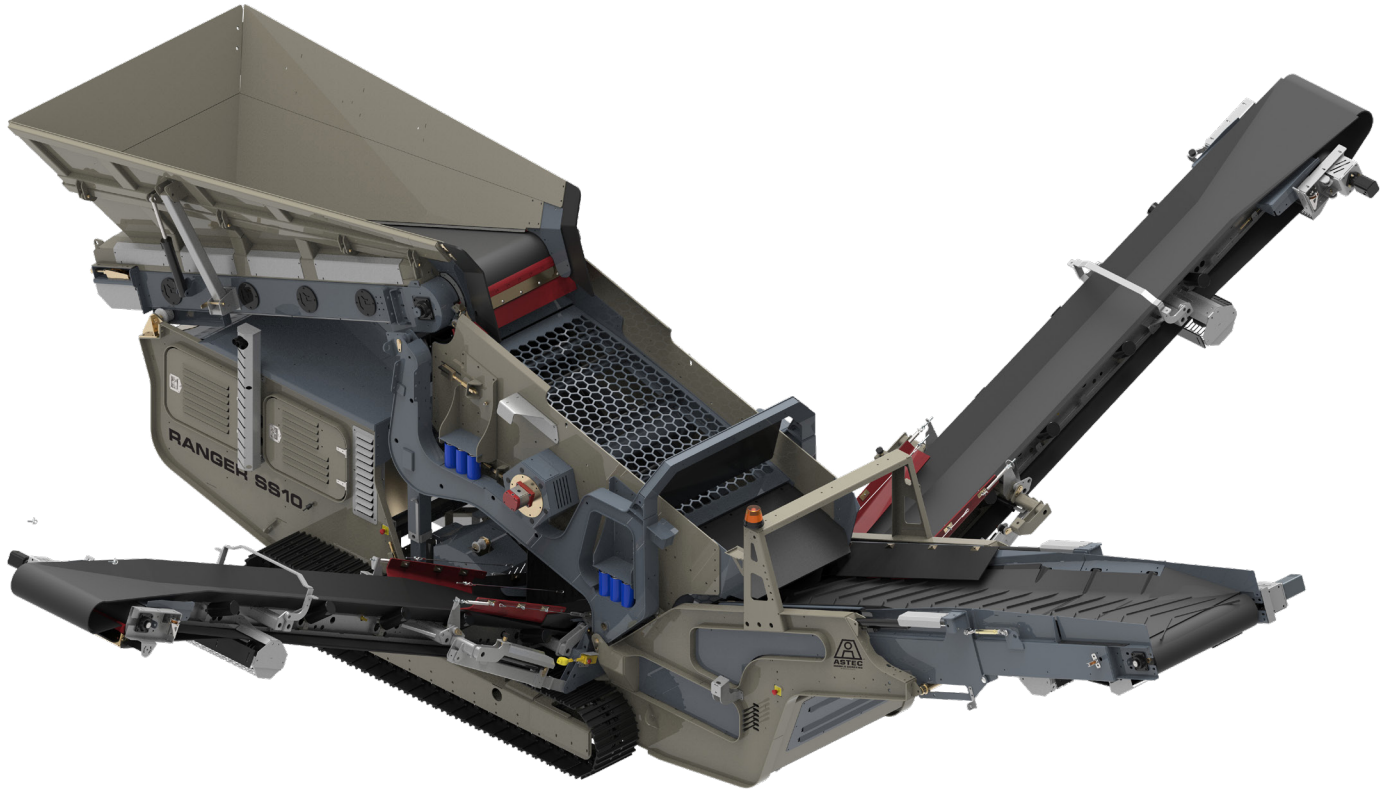

### Hopper/Feeder

- 14' x 40" (4,267 x 1,000mm) belt feeder
- Hydraulic variable speed drive
- 5.25 cubic yard (4 cubic meter) hopper capacity
- Hydraulically lowering hopper sides for transport

### Overs Conveyor

- 20' x 40" (6,096 x 1,000mm) conveyor with hydraulic drive
- 2-in-1 conveyor for mixing oversized and midsized product
- Discharge height 8' 8" (2,638mm)

### Bottom Deck Overs Conveyor

- 28' x 30" (8,534 x 750mm) conveyors with swing out design
- Hydraulic drive with variable speed
- Discharge height: 9' 5" (2,880mm)

### Power Unit

- Deutz D2011 L04i (EPA Tier 3) 49hp (36kw)
- Deutz TCD2.2 L3 (EU Stage V, EPA Tier 4) 74hp (55kw)
- Deutz TD2.9 L4 (EU Stage V, EPA Tier 4) 74hp (55kw)
- 26 gal (100L) fuel tank
- 100 gal (380L) hydraulic oil reservoir

### Fines Conveyor

- 28' x 30" (8,534 x 750mm) conveyor, swing out design
- Discharge height: 9' 5" (2,880mm)

### Overs Conveyor (3 Deck Unit)

- 20' x 20" (6,096 x 500mm) conveyor
- Discharge height 10' 1" (3,100mm)
- Hydraulically-folds for transport

### Vibrating Screen

- Bolted, 2-deck, 2-bearing high vibration screen
- 4' x 10' 6" (1,200 x 3,200mm) screen box

## Options

- Wireless track remote
- Screen media
- Twin shaft shredder
- Protection row 2" (50mm) spacing
- Screen platform
- Top spin filters (for dusty applications)
- Hybrid power
- Magnet on all conveyors
- Picking station with cover

## Physical/Operating Characteristics

Dimension	Standard	Metric
Operating Length	35'	10.7m
Operating Width	37' 6"	11.4m
Operating Height	9' 10"	3.1m
Travel Length	34' 10"	10.6m
Travel Width	7' 5"	2.3m
Travel Height	8' 5"	2.6m
Unit Weight	30,865lb	14,000kg
Feed Height (Front Feed)	9' 10"	3.1m

