

# CON-E-CO

## Mobile 450 Cement Bin

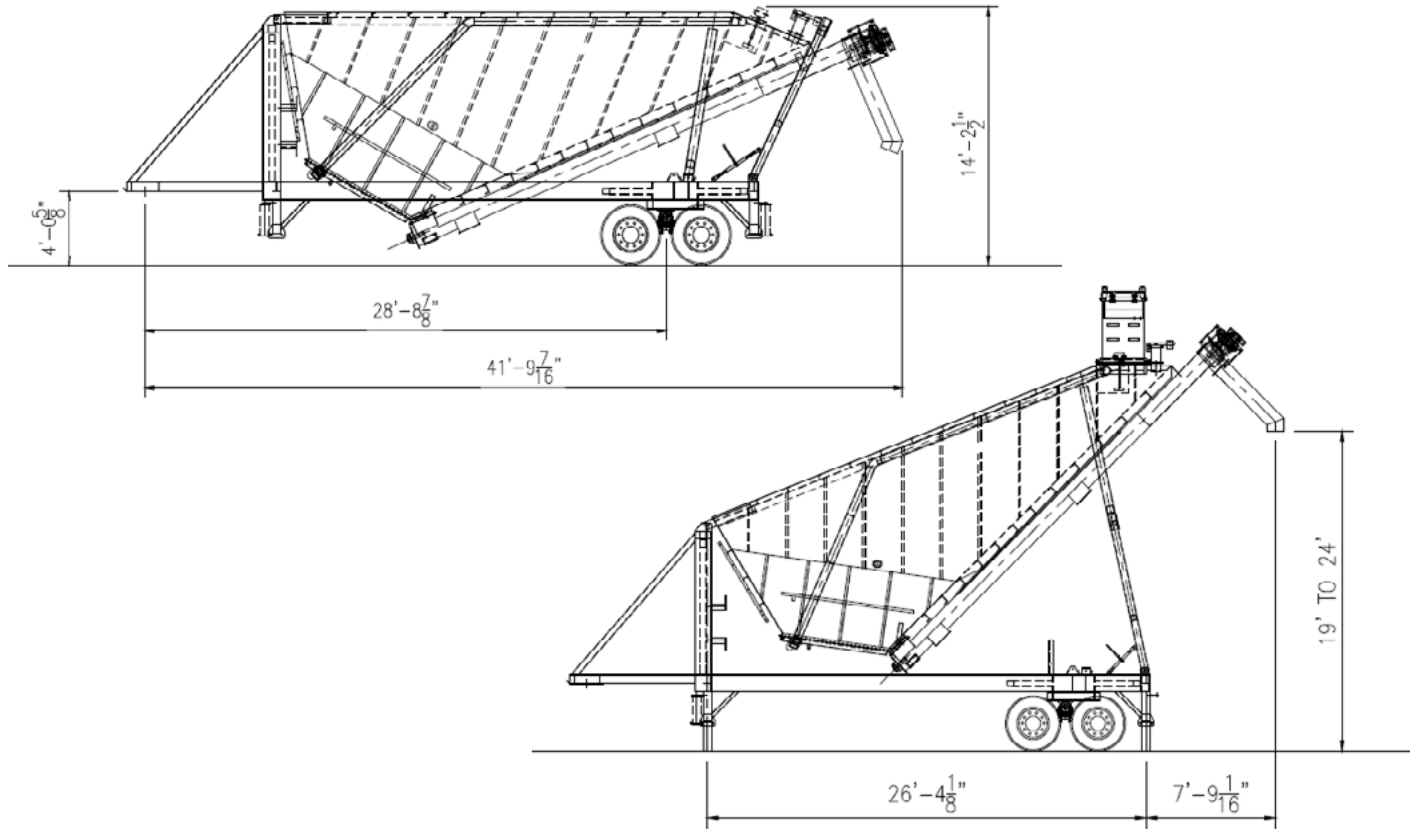

### STORAGE BIN CAPACITY:

CEMENT	GROSS VOLUME
	1,800 cubic feet
	45 cubic meters

### CEMENT FEEDER SCREW:

9" diameter (230 mm), 20 horsepower drive.  
Optional 12" diameter (300 mm), 40 horsepower.

### CEMENT AERATION:

5 horsepower, high volume, low pressure blower.

### ELECTRICAL:

460 volt, 3-phase with 120 VAC transformer for control voltage. All motors are TEFC. All motor circuit wiring protected by individual circuit breakers. Electrical components housed in NEMA steel enclosures. Wiring in conduit.

### TRANSPORTATION SYSTEM:

Rear-mounted 36,000 lb (16,330 kg) capacity single axle with eight (8) 255/70R 22.5 tires, wheels, air brakes, heavy duty spring suspension, tail and brake lights, and fifth wheel rub plate with king pin.

### DIMENSIONS:

Towing length	41'-10" (12,750 mm)
Towing height	14'-3" (4,369 mm)
Towing width	12'-0" (3,658 mm)
Empty weight, total	30,000 lb (13,607 kg)

### SHIPPING DIMENSIONS:

Length	43'-0" (13,106 mm)
Height	14'-3" (4,369 mm)
Width	12'-0" (3,658 mm)
Shipping Volume	7,353 cubic feet (208 cubic meters)

