

# BMH SYSTEMS ROLLMASTER REVERSING DRUM MIXER



# ROLLMASTER®

## High-Performance Reversing Drum Mixer

### There is only one Rollmaster®

The RollMaster was introduced to the industry by BMH Systems in 1999. While others have attempted to imitate the RollMaster, they are simply behind before they begin. The RollMaster is under constant evaluation by the same group of talented and forward-thinking professional Engineers that created it. They are able to build upon decades of industry use to re-innovate the innovation that is continuing to change the industry!

### Reduced Maintenance Costs

Extremely sturdy and efficient, its design keeps your maintenance costs to a minimum, saving up to 50% on maintenance costs over traditional mixers.

### Increased Production Capacity

Exclusive blade arrangement produces flawless concrete mixes in record time. Designed to allow for accurate slump control by using the motor's power reading. Produces RCC to high slump concrete without spillage.

### High Return on Investment

Beneficial in every regard, the RollMaster is paving the way to maximum profitability. Allows additional trips per truck, thus providing greater profits while reducing truck fuel consumption and increasing truck barrel longevity.

### Better Environmental Results

The RollMaster is designed to meet the strictest environmental standards. It keeps noise and dust to a minimum, making it the most environmentally efficient mixer in the industry. It discharges directly into the mixer truck via an enclosed chute, for better quality control and less concrete returns.



### Smoothness and Precision

Designed for today's fast-paced world, the RollMaster is a revolution in itself. At the heart of profit-driven batch plants, its ingenious design combines simplicity of use with outstanding performance. Quiet to run, it operates with smoothness, efficiency and precision. Built for results, its innovative blade shovel system provides optimal charging, mixing, discharging and cleaning.

### Simply Revolutionary

BMH has developed the optimal mixing technology for the ready mix industry, the RollMaster. This heavy-duty, high-capacity reversing drum mixer does not tilt. It rotates forward at full speed for charging and mixing and reverses rotation at variable speed for discharging.

Mounted on solid urethane tires, the drum rotates with less noise and vibration than any other mixer on the market. Costly ring gears and gear head motors are eliminated. The blade shovel system provides efficient charging, mixing and discharging, as well as easy cleaning.

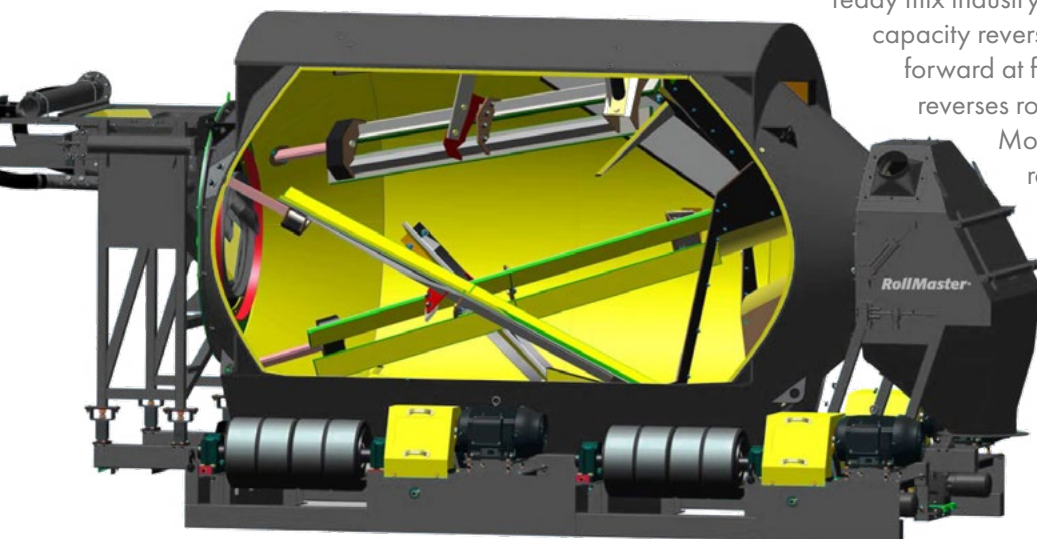

**RollMaster**

## Designed for performance

Mounted on solid urethane tires, the drum rotates with less noise and vibration. Costly ring gears and gear head motors are eliminated. Its innovative blade shovel system provides optimal charging, mixing, discharging and cleaning.

- Parts available locally
- Rapid discharge at variable speeds
- Fewer moving parts lead to a reduction in maintenance
- Shorter mixing time thanks to a unique blade arrangement
- Can mix 1" (25 mm) slump concrete at 100% mixing capacity
- Can batch up to 16 yd<sup>3</sup> (12 m<sup>3</sup>) of 12" (300 mm) slump concrete without spillage
- Desired concrete slump is easily obtained with motor's power reading

**Sized to fit**  
YOUR NEEDS

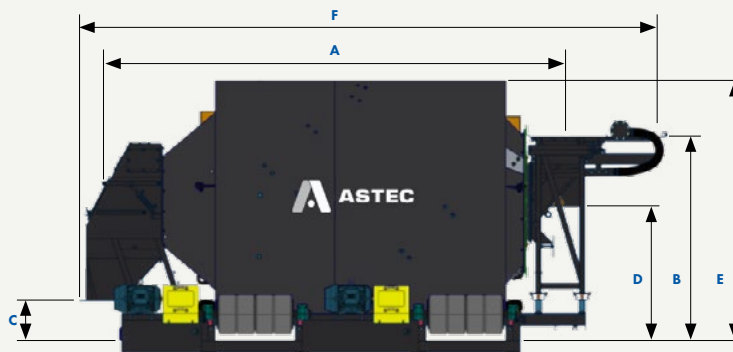

Size	4 yd <sup>3</sup> 3 m <sup>3</sup>	6 yd <sup>3</sup> 4.5 m <sup>3</sup>	8 yd <sup>3</sup> 6 m <sup>3</sup>	10 yd <sup>3</sup> 7.5 m <sup>3</sup>	12 yd <sup>3</sup> 9 m <sup>3</sup>	14 yd <sup>3</sup> 10.5 m <sup>3</sup>	16 yd <sup>3</sup> 12 m <sup>3</sup>
<b>Drum Diameter</b>	8' 3" 2.50 m	9' 2" 2.80 m	10' 4" 3.15 m	11' 0" 3.35 m	11' 0" 3.35 m	11' 0" 3.35 m	11' 0" 3.35 m
<b>Drive</b>	2 x 30 hp 2 x 22 kW	4 x 25 hp 4 x 18 kW	4 x 30 hp 4 x 22 kW	4 x 40 hp 4 x 29 kW	4 x 50 hp 4 x 37 kW	4 x 60 hp 4 x 45 kW	4 x 75 hp 4 x 55 kW
<b>A</b>	14' 10" 4.52 m	16' 8" 5.08 m	18' 6" 5.64 m	19' 4" 5.89 m	21' 4" 6.48 m	22' 8" 6.91 m	24' 9" 7.54 m
<b>B</b>	8' 1" 2.45 m	8' 5" 2.57 m	9' 4" 2.83 m	10' 0" 3.05 m	10' 0" 3.05 m	10' 0" 3.05 m	10' 2" 3.08 m
<b>C</b>	0' 9" 0.23 m	1' 2" 0.34 m	1' 9" 0.52 m	2' 5" 0.74 m	2' 5" 0.74 m	2' 5" 0.74 m	2' 7" 0.77 m
<b>D</b>	5' 4" 1.63 m	5' 9" 1.74 m	6' 4" 1.92 m	7' 0" 2.13 m	7' 0" 2.13 m	7' 0" 2.13 m	7' 2" 2.16 m
<b>E</b>	9' 6" 2.88 m	10' 4" 3.14 m	11' 6" 3.49 m	12' 6" 3.81 m	12' 6" 3.81 m	12' 6" 3.81 m	12' 8" 3.84 m
<b>F</b>	20' 4" 6.18 m	22' 2" 6.74 m	24' 1" 7.34 m	24' 11" 7.59 m	26' 11" 8.20 m	28' 3" 8.60 m	30' 7" 9.32 m
<b>Capacity per hour</b>	120 yd <sup>3</sup> 90 m <sup>3</sup>	180 yd <sup>3</sup> 135 m <sup>3</sup>	240 yd <sup>3</sup> 180 m <sup>3</sup>	300 yd <sup>3</sup> 225 m <sup>3</sup>	360 yd <sup>3</sup> 270 m <sup>3</sup>	420 yd <sup>3</sup> 315 m <sup>3</sup>	480 yd <sup>3</sup> 315 m <sup>3</sup>
<b>Weight</b>	26,400 lb 12,000 kg	33,000 lb 15,000 kg	40,000 lb 18,000 kg	46,500 lb 21,000 kg	53,500 lb 24,300 kg	56,500 lb 25,700 kg	60,000 lb 27,300 kg

## Features

- 1" (25 mm) thick steel shell fully lined with 1" (25 mm) abrasion-resistant urethane
- Rapid discharge rate
- No vibration, quiet operation
- Mounted on solid urethane tires
- Low maintenance costs with fewer moving parts
- Shorter mixing time thanks to a unique blade arrangement
- Direct relation between concrete slump and motor current
- Cement, aggregates and water are loaded directly into the mixer
- Power panel 480 or 575 volts. Other voltages available.
- Can mix 0" slump concrete at 66% of its mixing capacity and 1" (25 mm) slump concrete at 100% capacity
- Two-way chute
- Can be used for dry batching in case of low or small yardage situations. With totally enclosed chutes, you can by-pass the RollMaster® and dry batch in a dust-free environment.

## Options

- Dust collector
- Two-way (dry batch) chute
- Telescopic and dry batch hood
- 2 x 3 hp (2.2 kW) emergency motors up to 12 yd<sup>3</sup> or 9 m<sup>3</sup> (connected to generator)



**ASTEC™**

[www.astecindustries.com](http://www.astecindustries.com)