

ROADTEC RX-405 COLD PLANER



RX-405 COLD PLANER

The RX-405 is a powerful yet compact milling machine. Powered by a 430 hp (321 kW) stage V engine, this lightweight cold planer cuts widths of 24 to 60 inches, up to 13 inches deep. A center-mounted, belt-driven cutter drum provides high productivity with exceptional balance. The RX-405 is the ideal solution for milling contractors who need flexibility and versatility.



VERSATILE APPLICATIONS

The versatile RX-405 cold planer is smaller than its full-lane class and half-lane class counterparts, making it ideal for a multitude of smaller-scale applications and perfect for contractors who require flexibility. From a 2-foot trench cut where you're only taking up enough material for utility work, all the way up to a 5-foot cut, the RX-405 excels in the following applications:

- Shoulder removal
- Trenching
- Parking lots
- Joint repair
- Tandem milling with a half-lane machine

OPTIMAL OPERATOR COMFORT

The RX-405 was designed with a focus on operator comfort and productivity. Ease of use is assured with intuitive control panels and camera displays. The control stations are grouped by function and the propel and conveyor controls are operated by different joystick types, making them more intuitive.

The operator does not need to sacrifice comfort for productivity on the RX-405. Both the seats and the control station can be adjusted to multiple settings and angles to suit a seated or standing position.

Beyond making the operator comfortable, the RX-405 provides clear and unobstructed sightlines, including a clear view of the endgate and the edge of the cut, all while maintaining a smooth operation.

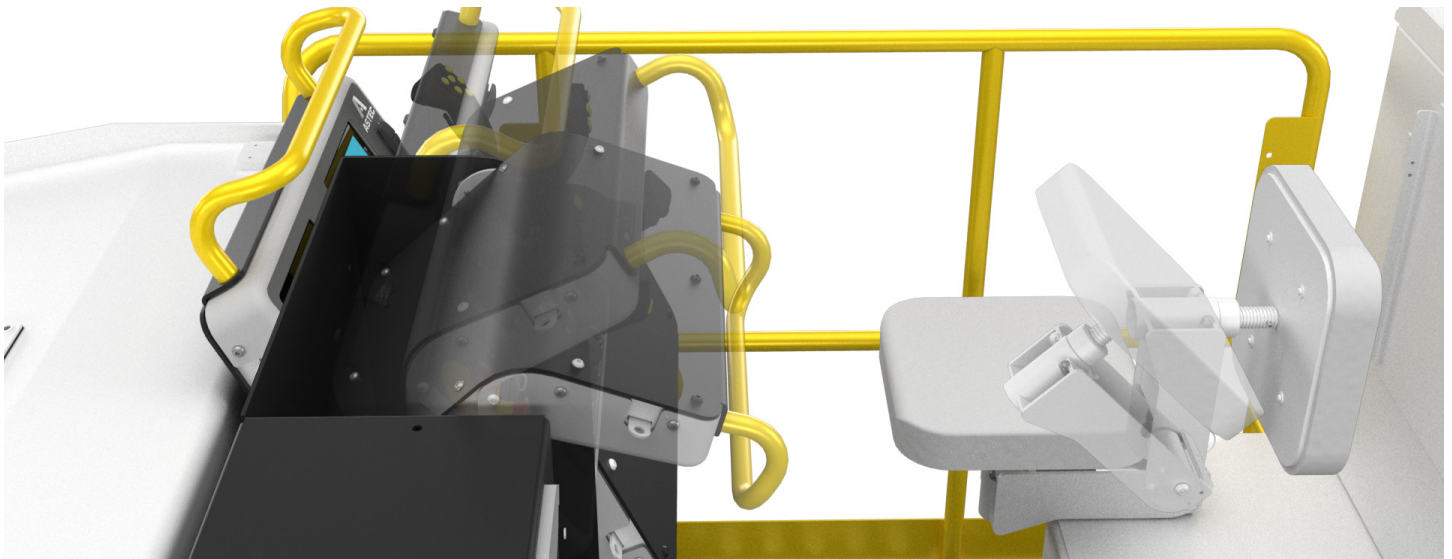

BUILT-IN VANDAL COVER PROTECTIONS

The operator station offers off-hours protection. When the workday is done, the entire console flips over for built-in vandal protection.

CAMERA PACKAGE

The backup camera on the RX-405 enhances productivity and comfort. The camera sends a video feed to a screen on the operator station. The camera provides a clear view of what is behind the machine and automatically appears when in reverse.

The operator can also select to view the feed at any time. The ability to view the camera at any time allows operators to work with confidence.

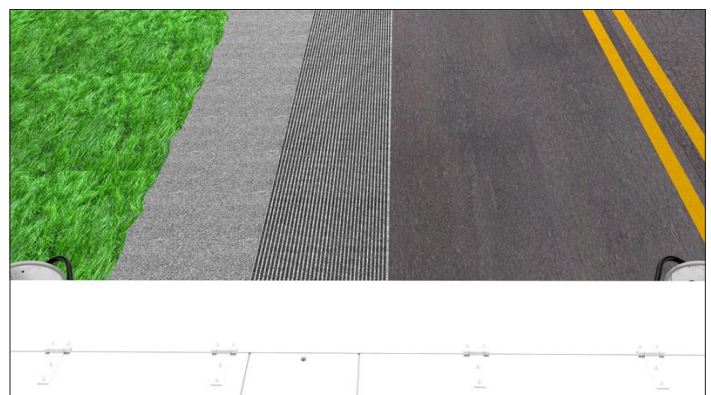

CENTER MOUNTED DRUM

The center-mounted cutter drum on the RX-405 offers increased maneuverability and stability. The ideal weight distribution and improved traction, coupled with a 5-foot cut capability, enables your crew to operate at maximum productivity.

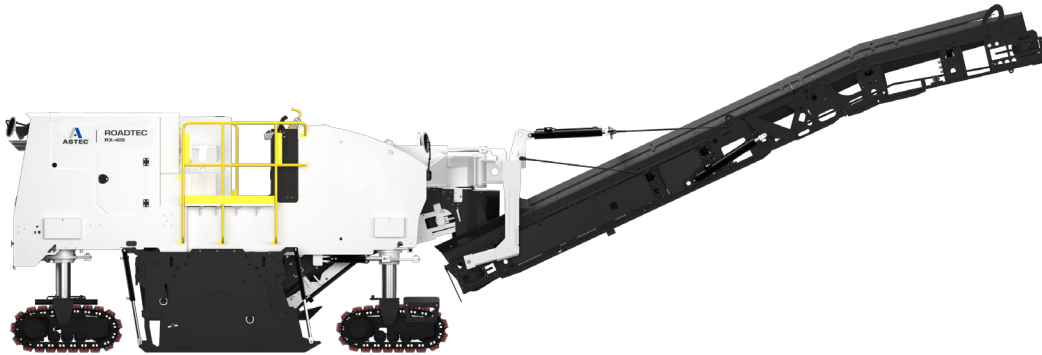

VARIABLE CUTTER SYSTEM

The RX-405's Variable Cutter System® (VCS) makes quick work of drum changes. This design also allows for greater material evacuation with a wider primary conveyor and 2 inches of overlap on the front moldboard that overlaps with the paddles on the drum even at narrow widths.

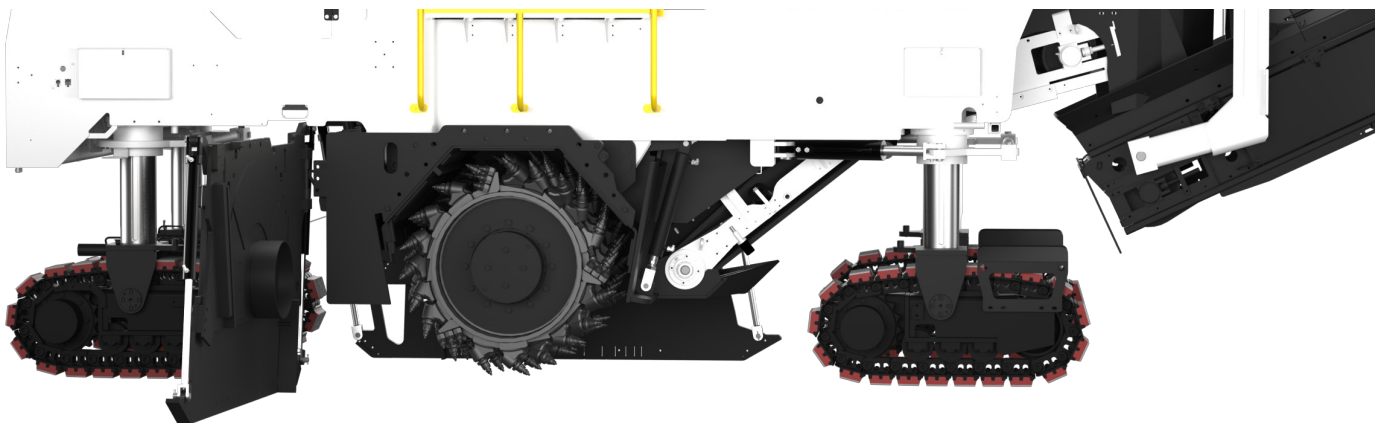
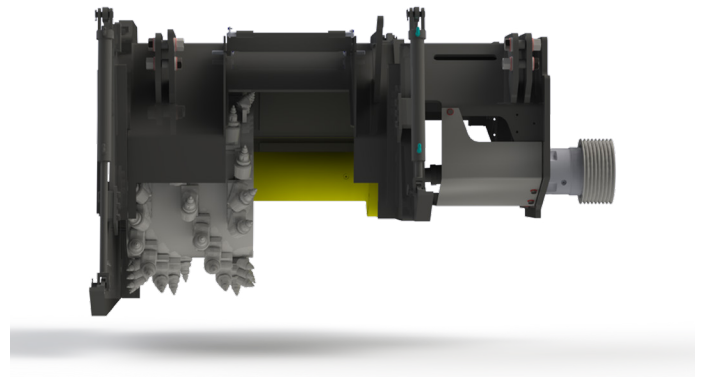

EASY ACCESS TO THE CUTTER DRUM

The hinged door on side of the cutter housing makes it very easy to access all parts of the cutter housing and change the drum. The single cutter housing can quickly transition from 2 feet to 5 feet wide. A segmented rear moldboard is a standard component to accommodate the various cut widths. The housing features a robust, belt-driven cutter drive.

DRUM INDEXER

Perform drum maintenance more confidently with the drum indexer system on the RX-405. The drum indexer is a pendant-controlled mechanism that rotates the drum independently of the cutter belt drive. The ability to rotate the drum while the drive belt is disengaged allows for cutter drum access and maintenance. The drum indexer allows the technician to easily line up the drum to where teeth need to be changed, without needing to manually pull on the drum.

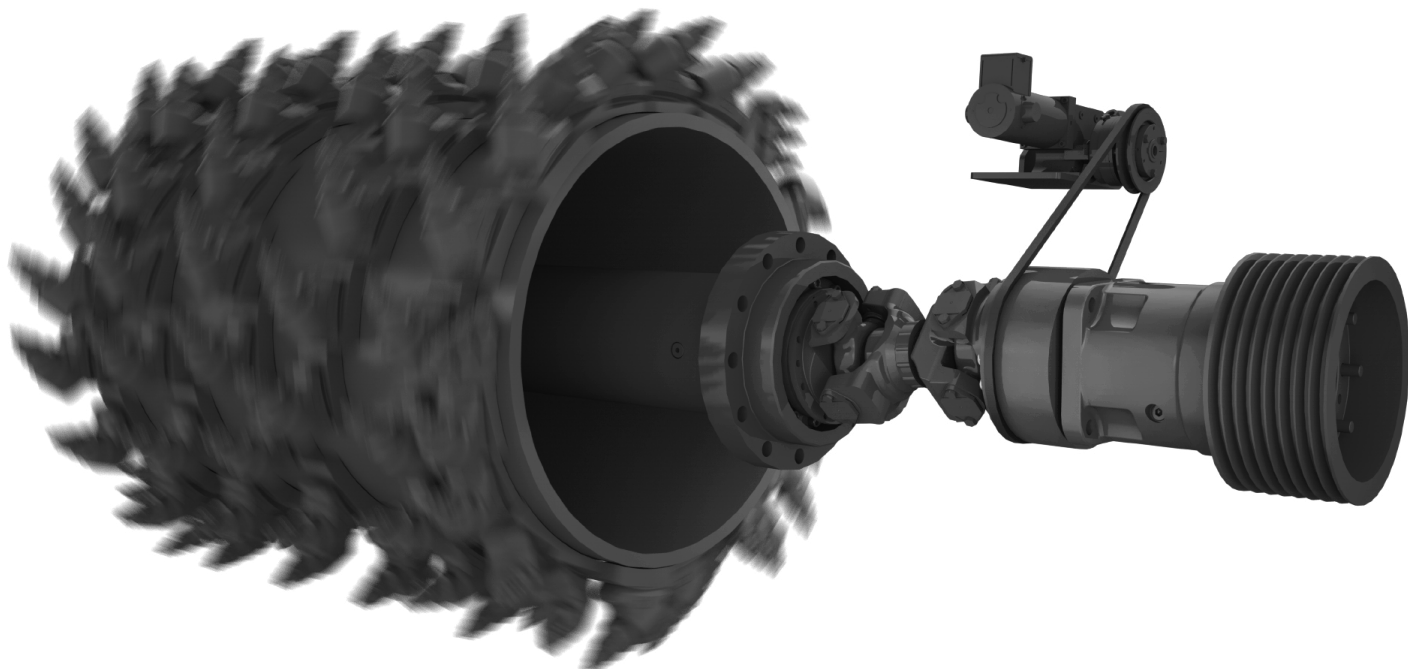

A magnetic-based pendant control box provides access and easy operation while under the machine.



KEY FEATURES

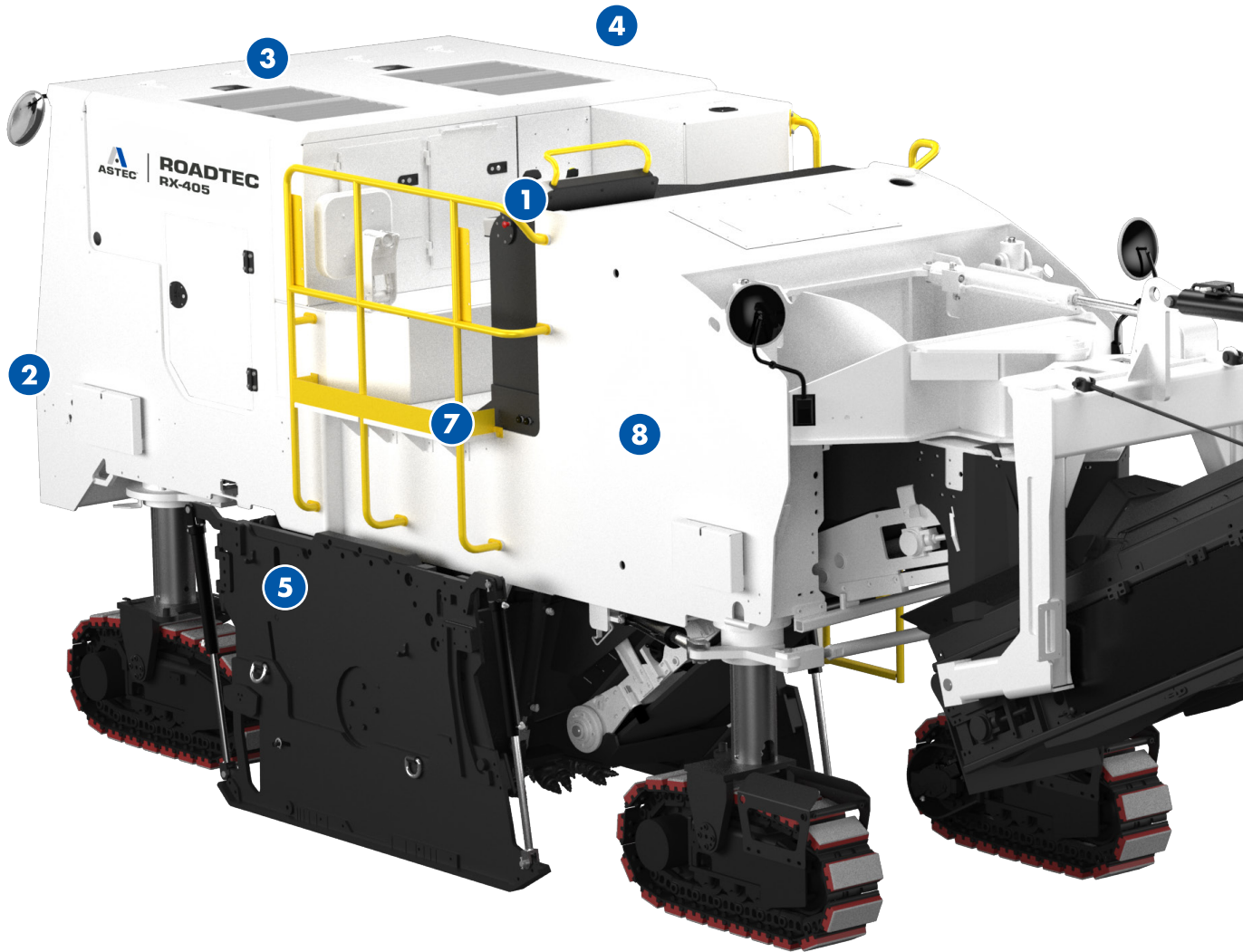

1 Ergonomic Controls

The angle of the control station can be adjusted to suit a seated or standing position.

2 Reverse Disable Buttons

When either button on the rear of the machine is engaged the mill will not allow the operator to move in reverse.

3 Rear Object Detection

Rear object detection uses a series of sensors and cameras to stop the machine if the sensors detect an object behind the machine while the machine is in reverse.

4 750 gallon water tank

Highest capacity in class allowing for a more efficient operation.



5 Hinged Door Access

Quickly access the cutter housing for easier maintenance.

6 Folding Conveyor

A folding secondary conveyor aids in transport and loading.

7 Vibration-Absorbing Platform

The vibration-absorbing platform ensures a smooth operator experience.

8 Drum Indexer

Advance the cutter drum during maintenance using a magnetic-based control box.

VERSATILE CONVEYORS

The RX-405 includes versatile and productive conveyors. Conveyors feature infinitely variable speeds and canvas covers. A wide conveyor design provides efficient material evacuation at all drum widths.

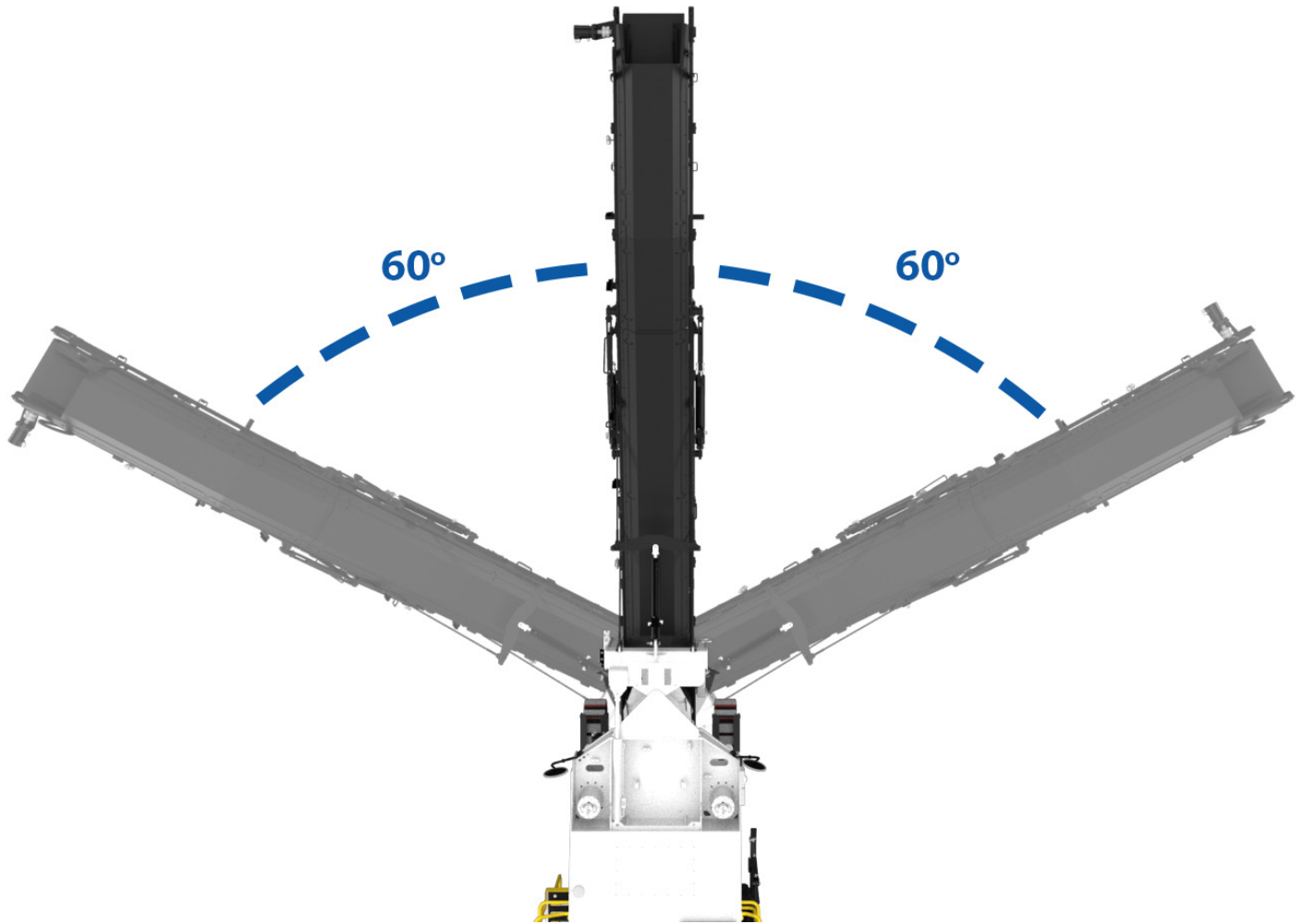

Self-Cleaning Pulleys

Each conveyor features self-cleaning pulleys, which release wet material to ensure maximum efficiency and help prevent excess wear.

Versatile Secondary Conveyor Swing

The secondary conveyor swings 60° to the left and right. This increased range makes it possible to mill tight turns and send material to trucks in an adjacent lane.

REAR OBJECT DETECTION

An optional rear object detection system provides an increased level of safety on the jobsite. This system is designed to stop the mill if a person or object is detected behind the machine while it is in reverse. Rear object detection uses a series of sensors and cameras to help the operator view the area behind the machine.



Red Light – Reverse Disabled. The machine will operate normally in forward motion, but will not reverse while the button is red.



Green Light – Normal Operation. The machine will operate normally in forward and reverse. Detection sensors are still active.

Reverse Disable Buttons

The RX-405 features reverse disable buttons on both sides of the rear of the machine. When either of those buttons is engaged, the mill will not allow the operator to move in reverse. If a crew member walks behind the machine, they can simply press the button on one side, move across the machine and press the button on the other side.

Reverse Override

In the event a job requires the operator to reverse the machine closer to an object than the sensors allow, a reverse override ability is accessible through the main control panel.

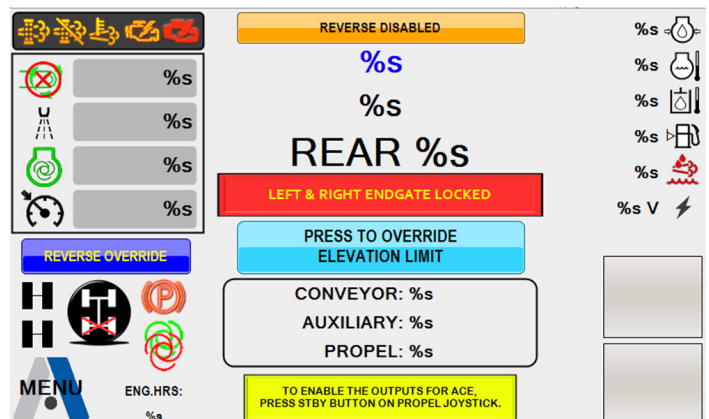

ACE AUTOMATED CONTROL OF ELEVATION

The RX-405 is equipped to use ACE, the Automated Control of Elevation® System that automates machine elevation through a combination of grade and slope sensors.

With ACE, your operator or ground crew can easily make changes to the grade and slope parameters in real time. Graphic displays allow the crew to easily select, calibrate and control sensors with minimal time and effort. The sensors used to measure depth and slope are continuously monitored and displayed on each control panel keeping your entire crew on the same page at all times.

ACE can be coupled with Astec's Auto Cut feature, which automates the machine's rear elevation as it enters each cut. Auto Cut uses technology to increase precision and reduce the effort required to resume cutting after beginning a new pass or encountering obstructions.



TELEMATICS

Protect your investment and keep operating costs low by monitoring your machines in real time with the Guardian® telematics system. This system includes software, on-machine viewing screens and wireless signal boosters to send and receive data from anywhere at anytime.

Guardian provides the data you need to make changes in real time to mitigate risks and increase profits. Guardian's intuitive Live Schematics™ lets owners and technicians view electrical circuits in a simple, efficient layout with live status of switches, valves and settings

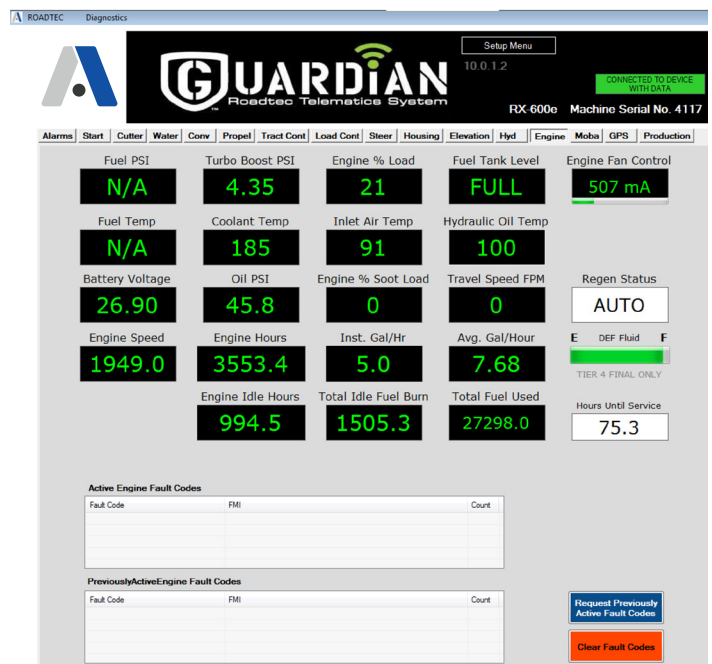

PHYSICAL AND OPERATING CHARACTERISTICS

Dimension	Imperial	Metric
Engine MFG	Cummins	
Model	L9	
Max Power	430 hp	320 kW
Number of Cylinders	6	
Electrical System	24 V	
Shipping Weight *	46,900 lb	21,273 kg
Shipping Length (Conveyor Folded)	34' 6"	10.52 m
Shipping Width	8' 2"	2.49 m
Shipping Height	9' 11"	3.02 m
Fuel Capacity	200 gal	757 L
Water Tank Capacity	750 gal	2,839 L
Hydraulic Tank Capacity	35 gal	132 L
Max Cut Depth	14"	356 mm
Travel	0 - 3.2 mph	0 - 5 kph
High working	0 - 163 fpm	0 - 50 mpm
Low working	0 - 110 fpm	0 - 34 mpm
Turning Radius	7'	2.13 m

*10% tank full; no water, cutter housing & drum

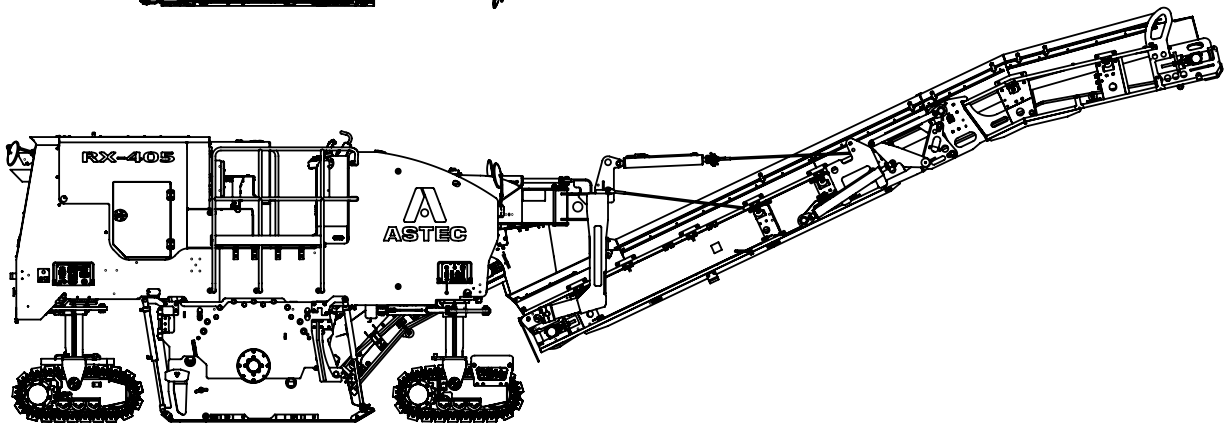
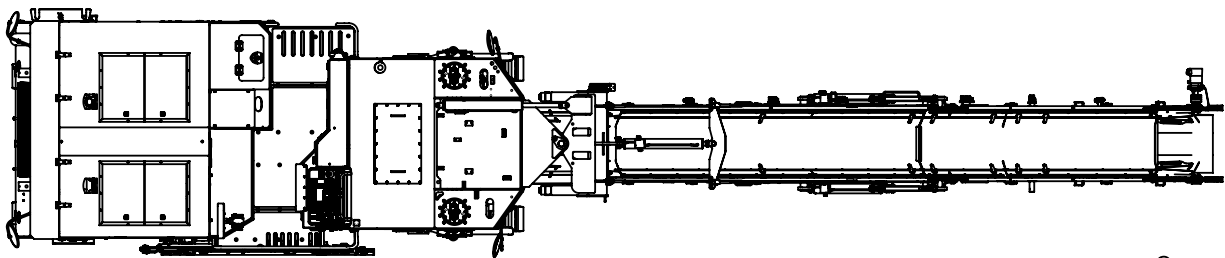



ASTEC

www.astecindustries.com